

Geo by EquiLift

DIMENSIONS

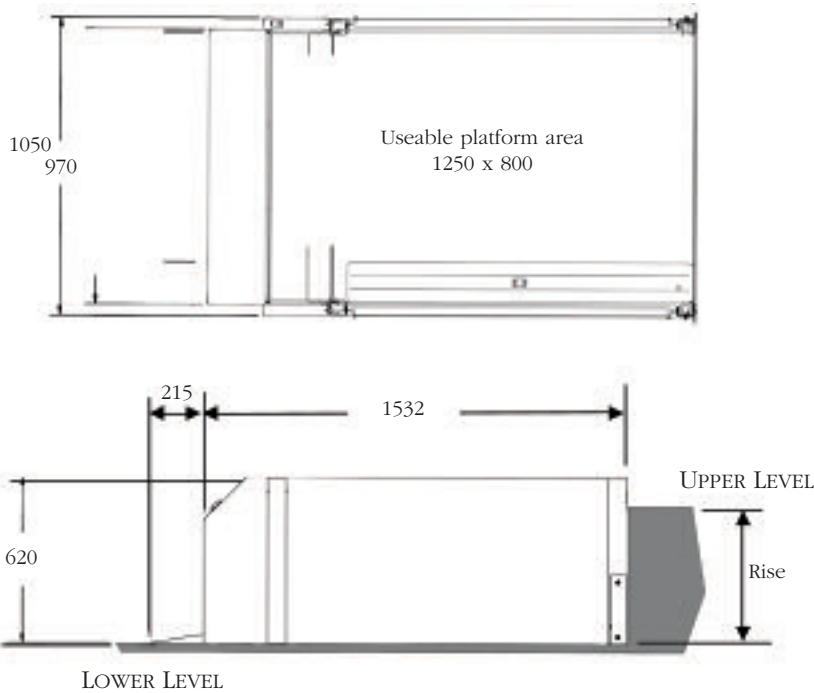

Adequate drainage is required to prevent water collection under the lift



Max rise:
290mm without upper level protection. 500mm with gate

All dimensions in mm

DIMENSIONS FOR GEO PORTABLE

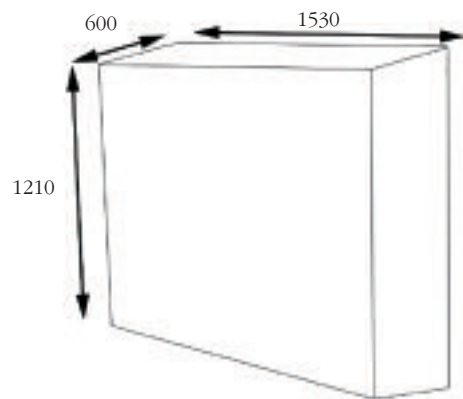
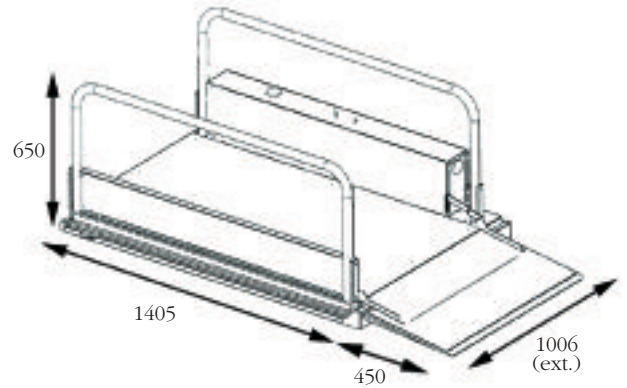

DIMENSIONS FOR GEO PORTABLE FOLDED

TECHNICAL DATA

Geo is a hydraulically operated scissor step lift capable of lifting 250kg up to 500mm between fixed levels.

Manufactured in:	UK
Lifting capacity:	250kg
Lifting height:	Max 500mm (up to 2m with Portable)
Operator Controls:	'Hold to run' buttons
Drive system:	Hydraulic drive system
Standard platform sizes:	1250mm x 800mm (l x w)
Electrical connections:	240V AC - 50/60 Hz
Speed:	Max 0.07 - 0.08 m/s
Control supply:	24V DC (lift control circuits are fed by a battery which must be kept on constant charge)
Hydraulic pump power:	600W max
Hydraulic oil grade:	T22
Technical compliance:	CE marked, BS6440
Colour:	Choice of RAL colours
Safety:	Full platform and ramp safe edges

Standard Specifications:	Shallow approach ramp
	Low closed height (75mm)
Main options:	Charger pack
	Free standing platform
	Powder coated finish over zinc plated steel to ensure maximum corrosion protection
	Handrails
	Single bridging step or interlocking gate assembly for use when rise exceeds 290mm
	Remote control operation
Warranty:	Key operated call station
	Choice of RAL colours
	12 months, when serviced by an authorised agent

All dimensions are approximate based on standard Geo product.

Information in this brochure is correct at time of print, but as we continually develop our products, we reserve the right to change specification without notice